



Product Information
Version 2.3

ZEISS Stemi 508

Your Apochromatic Stereo Microscope with 8:1 Zoom
for Excellent Image Contrast and Color Accuracy



Your Apochromatic Stereo Microscope with 8:1 Zoom for Excellent Image Contrast and Color Accuracy

- › In Brief
- › The Advantages
- › The Applications
- › The System
- › Technology and Details
- › Service

Stemi 508 is compact, reliable and equipped with optics and mechanics designed for heavy workloads. With the large 36 mm object field you always keep the overview of your sample. The 8:1 zoom then allows to bring details up to 50x magnification. You even have larger samples? Add interchangeable optics and observe an area of up to 122 mm, making Stemi 508 a top performer in its class. Stemi 508 offers better ergonomics than any other Greenough-type stereo microscope: The low viewing angle of 35° lets you keep a relaxed posture even after hours of work.

With Stemi 508 you observe and document your samples exactly as they are: rich in detail, sharp in focus and free from distortion or color fringes. Stemi 508 is your robust all-rounder for everyday lab work and industrial inspections: accurate, ergonomic – and always easy to use.



Simpler. More Intelligent. More Integrated.

- › In Brief
- › **The Advantages**
- › The Applications
- › The System
- › Technology and Details
- › Service

Large 8:1 Zoom with Apochromatic Correction

Stemi 508's apochromatic zoom optics and efficient stray light suppression give you a crisp three-dimensional image. You visualize your objects distortion-free and without color fringes, in fields of view up to 122 mm. The large 8:1 zoom lets you observe even minute structures in high contrast. Select from a range of apochromatic front optics and eyepieces to reach any magnification between 2x and 250x. Double your resolution or enjoy large working distances up to 287 mm without compromising optical quality – it's your choice.



Precise Mechanics for Heavy Workloads

Stemi 508 is designed for heavy workloads, using durable and reliable mechanics. Its precise zoom adjustment ensures a well-balanced 3D impression: enjoy relaxed stereo viewing without eye-strain. Whether you zoom continuously variable or in reproducible mode activating click stops – the image stays sharply focused over the whole magnification range. You often work on the microscope for long hours and appreciate a comfortable posture. The low viewing angle of 35° makes Stemi 508 more ergonomic than other Greenough-type stereo microscopes.



Created for All Your Applications

Choose from a wide range of different stands and accessories to get exactly what you need for your application. From compact stands to flexible and stable boom stands, from basic transmitted light to polarization contrast. Whether your object needs special illumination or simply the brightest light – you have various fiberoptic light guides and LED illuminators to choose from. Position your specimen precisely by adding a gliding, tilting or rotating polarization stage. Via interchangeable camera adapters, Stemi 508 can be combined with any ZEISS Axiocam camera and most DSLR cameras or camcorders. A c-mount adapter 0.5x for Axiocam cameras up to chip size 1/2" is always included.



Your Insight into the Technology Behind It

- › In Brief
- › **The Advantages**
- › The Applications
- › The System
- › Technology and Details
- › Service

Greenough Stereoscopic Design

The basic idea behind a stereoscopic microscope is simple. It was formulated in 1896 by the biologist Horatio S. Greenough, who wanted to see small biologic samples magnified, but with the same quality as with unaided eyes. In other words: in three dimensions and with all the depth information he needed to understand the irregular shape of his specimen intuitively. He reckoned, one could build a microscope with two separate beam paths facing the object from two directions - exactly as human eyes do when observing a small object at a distance of 250 mm. The brain would fuse the two images together and produce a spatial image of the object with a high degree of depth perception. This thinking led to the first factory-produced stereo microscope being developed by ZEISS.

Stemi 508 is a Greenough-type stereo microscope, utilizing long working distances for easy specimen handling and large fields of view. It is compact, rugged and simple to use – and so typically employed for heavy workloads in routine microscopy, such as printed circuit board inspection or dissecting biological specimens.

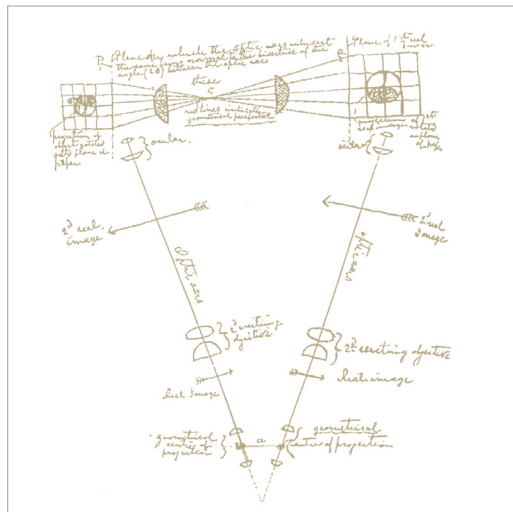

Hand drawing by Horatio S. Greenough (1896), leading to the world's first industrially-manufactured stereo microscope.



ZEISS Stemi 508 features a Greenough optical system with powerful 8:1 zoom. The twin body tubes are inclined by an angle of 11° – for an impressive stereoscopic image impression.



Schematic beam path of a Greenough type stereo microscope.

Your Insight into the Technology Behind It

- › In Brief
- › **The Advantages**
- › The Applications
- › The System
- › Technology and Details
- › Service

Apochromatic Optics for Images Free of Color-fringes

Producing microscopes with pre-calculated optical characteristics based on Abbe's calculation was already a huge step for ZEISS. But, especially working with large apertures, Abbe recognized aberrations he called "chromatic differences of spherical aberrations" caused by the quality of the optical glasses. As a result, different colors of light focus at different distances from the objective. Observed through a microscope, objects appear to have colored fringes! It was already known that chromatic aberrations can be reduced by combining glasses with differing dispersion – eg achromatic doublets made of crown and flint glass – but to further increase the degree of chromatic correction,

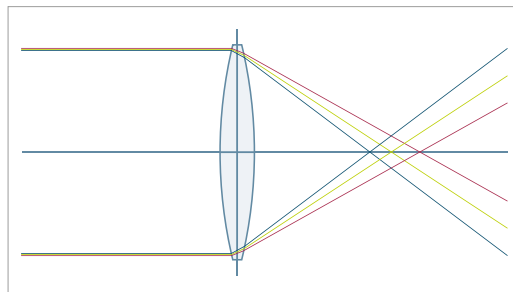

Chromatic aberration

a larger number of lenses and optical glasses with special dispersive properties were needed. Only with the development of new optical glasses by Otto Schott, the production of apochromatic objectives by Carl Zeiss (based on the calculation of Ernst Abbe) could be commercialized. Apochromatic objectives correct the lens aberrations for three colors of the visual spectrum (red, green and blue) by bringing the three wavelengths into focus in the same plane. Apochromatic objectives therefore produce images which are sharper and more brilliant. Therefore these objectives are favourable, whenever image quality is of importance doing evaluations and documentation.

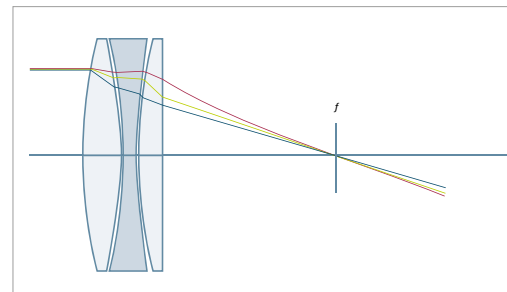

Lenses with apochromatic correction

1886

First apochromatic microscope objective, color corrected for three wavelengths based on the calculations of Ernst Abbe.

The foundation for this achievement was in part formed by the concerted attempts of Abbe and Schott to improve optical glasses.



Your Insight into the Technology Behind It

- › In Brief
- › **The Advantages**
- › The Applications
- › The System
- › Technology and Details
- › Service

White LEDs Replace Halogen Light for Microscopy Lighting

LEDs – light emitting diodes – are semiconductor diodes that emit visible light when a forward electric current is applied. The color of the light is nearly monochromatic and determined by the semiconductor material. To produce white light, blue LED chips are combined with different phosphors that convert a fraction of the blue light to longer wavelengths. The resulting LEDs show a broad, continuous emission spectrum. Given their excellent properties, white LEDs have largely replaced halogen lamps as standard illumination in stereo microscopy: White LEDs can be perfectly integrated into microscope stands since they are compact, maintenance-free and noiseless, and they don't generate vibration either. Since it doesn't contain any infrared or ultraviolet parts,

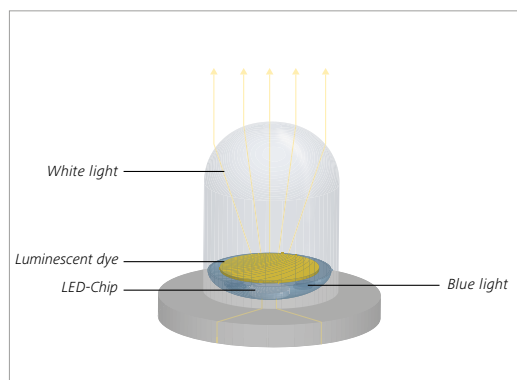

Typical design of white LEDs: a blue LED chip is coated with yellow phosphors that partly convert the blue light to longer wavelengths.

white LED light contrasts your objects in a gentle way. Since LEDs rarely ever fail, their lifetime is defined by “lumen maintenance”, which is the operating time until the initial light output has degraded to 70 %. At ZEISS we specify 25,000 hours equivalent over 12 years (a 5 day week, 8 hours per day). Modern white LEDs feature high brightness and daylight quality (CCT 5000 – 6000 K), they are energy saving (their luminous efficiency already reaches fluorescent tubes) and convince with very short switch-on times. Even in the most intense fiber optic cold light sources, innovative high power LED packages have replaced 150 W and 250 W halogen reflector bulbs – as in our ZEISS CL 6000 LED and CL 9000 LED cold light sources.

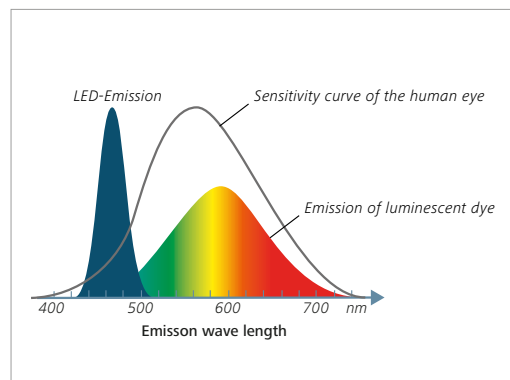

Spectral distribution of a phosphor-based white LED: blue LED light combines with a broadband phosphor spectrum.

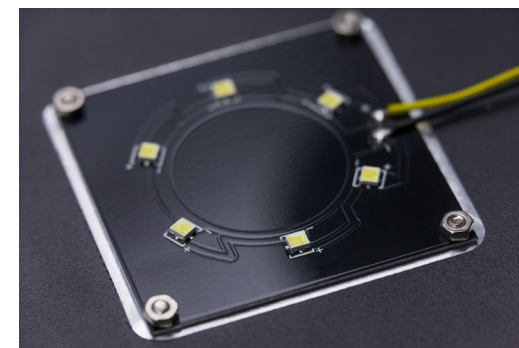

The flat transmitted light unit in stand K EDU is powered by six white High Brightness LEDs. The LEDs are directly mounted on a printed circuit board. It's black color gives the dark background needed for transmitted light darkfield contrast.

Expand Your Possibilities

- › In Brief
- › **The Advantages**
- › The Applications
- › The System
- › Technology and Details
- › Service

Stand M – Generous Sample Space. Large Focusing Range. Including LED Illumination.



Stemi 508 is a high quality stereo microscope that's highly suitable for the most demanding tasks in laboratory work as well as industrial failure analysis. And a sophisticated microscope needs a coequal stand: Stand M offers generous specimen space and a large focusing column. On the other hand, Stand M is compact enough to be used in small lab rooms - all the more, since LED electronics are integrated and thus no external light sources necessary. Stand M LED controls up to two reflected light LED illuminators and transmitted light in parallel. Mix their illumination to optimally contrast your specimens, store the settings by a button press – and quickly switch between your light scenarios by using the memory section of stand M LED.

To optimize Stemi 508 to your applications' needs, you can choose from a range of changeable LED illuminators. All of them use intense white LEDs – long life, maintenance-free and of daylight quality.

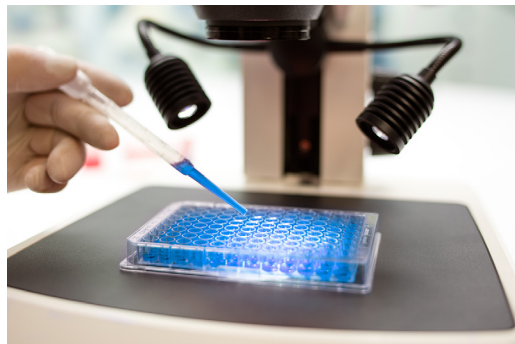

ZEISS Stemi 508 with stand M provides a large sample space. Easily handle large specimen or several Petri dishes in parallel. Cope even with big industrial workpieces.



The memory section of stand M LED allows storing and quick recall of up to three customer specific illumination conditions. Press an "M" key long to store, press it short to recall your individual light scenario.



Stand M LED can easily be equipped with transmitted light: Choose between mirror-based transillumination unit M LED or the flat brightfield-darkfield transilluminator, that is integrated in the stand base without adding height.

Expand Your Possibilities

- › In Brief
- › **The Advantages**
- › The Applications
- › The System
- › Technology and Details
- › Service

Stand K – Compact. Easy to Use. All-in-One Design.



Workspace is limited in your lab or quality department? Do you usually stow away your systems and set them up again? Or you often work with untrained or multiple users? – In all these ways, the stand K line is made for you. With its small footprint and integrated LED illumination, a K stand turns your Stemi 508 into a compact all-in-one device that's easy-to-use and quick to pack up and reinstall wherever it's needed. To ensure the integrated LED illumination is optimized to your application range, choose from different stand versions.



Stand K EDU with flat transmitted light unit and carrying handle for easy transport is your compact choice for classroom environments. Add a single spot illuminator K LED to study your opaque specimen in strong 3D contrast.



Stand K LAB's compact transillumination base with tiltable mirror features brightfield, one-sided darkfield and oblique light. Add the double spot illuminator K LED for reflected light dissections.



Stand K MAT is equipped with reflected light LED controls and ESD features (antistatic coating), and thus optimizes your Stemi 508 for PCB inspection and small parts assembly in electronics industry. Add the segmentable ringlight K LED as illumination – and a gliding or tilting stage, if precise positioning of your specimen is needed.

Expand Your Possibilities

- › In Brief
- › **The Advantages**
- › The Applications
- › The System
- › Technology and Details
- › Service

LED Illuminators K/M - Bright. Longlife. Changeable at Your Choice.



▶ [Click here to view this video](#)

LED spot illuminator – Change angle and height of the spot and zoom it – to create distinct shadows for a strong 3D impression. In the lowest position it delivers a grazing light that enhances fine structures on flat surfaces.

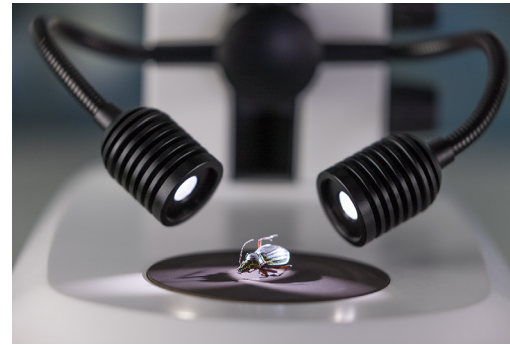

Double Spot K LED – For sample preparations in reflected light, the double spot illumination with self-carrying goosenecks is optimal. It creates half-shadow effects that lead to a good 3D impression. During dissections the specimen stays illuminated even if the manipulating hand covers one of the spots.



▶ [Click here to view this video](#)

Segmentable ringlight – The segmentable ringlight features four segment modes: full-, half- and quarter-circle and 2-opposite quarters. Push a key to turn the light direction manually in 90° steps and quickly inspect for scratches, defects or residues. Using auto rotating mode, you get a spatial impression of the object surface due to constantly moving shadows.



Transillumination unit M LED – The tiltable and shiftable mirror features brightfield, one-sided darkfield and oblique light. Rotate to plain and frosted mirror side, then decide between crisp and diffuse brightfield contrast. Add polarizing contrast as an option.



▶ [Click here to view this video](#)

Flat transilluminator brightfield / darkfield – Use the flat transmitted light module to contrast colored transparent specimens in bright- and darkfield. Add polarizer/analyzer equipment to observe, for example, birefringent crystals or tensions in glass or plastics.



Controller K LED – Enables standalone use of the segmentable ringlight, for example when Stemi 508 is used with boom stands.

Expand Your Possibilities

- › In Brief
- › **The Advantages**
- › The Applications
- › The System
- › Technology and Details
- › Service

Boom Stands – Stable. Flexible. With Large Operating Range.



There are various types of 3D shaped objects in stereo microscopy, and the applications are yet more diverse, since different customers may ask for different object details, even when working with the same specimen: Your objects may be much larger than the footprint of any desktop stand. Or you may have to investigate small specimens in a very large area of interest. Or... you may be sharing your Stemi 508 with several colleagues and need to swing your microscope between their workplaces. You could be, for example, a veterinary surgeon, forensic specialist, restorer, archeologist or dental technician. Your applications will need a large boom stand! Big stands with extension arms make it easy to move your Stemi 508 to any point in a large operating range. It always remains stable enough to observe small object details in a smooth stereo image. Choose from the cost-effective boom stand B with a single extension arm, the stable and easy-to-move "double arm" boom stand SDA – or the large floor stand S! It's spring-balanced tilting arm, well balanced in height and most flexible, adjusts to each point in a large specimen volume! Since you will also need a large, free working distance, we recommend to add front optics 0.3x, 0.4x or variable front lens.



The mobile floor stand S covers a larger specimen space than any other stand available for Stemi 508. It is used to observe tall, heavy or irremovable specimens like car engines, large animals, living plants, sculptures or wall paintings.



The ball bearing horizontal arm of the double arm boom stand SDA ensures a large travel range and feather-light movement. Focusing your specimen via the variable front lens (instead of using the focus drive) ...



[▶ Click here to view this video](#)

... will keep your actual viewing height constant! You profit from better ergonomics: Specimens with a maximum height difference of 143 mm can be focused without changing the viewing height of your Stemi 508!

Expand Your Possibilities

- › In Brief
- › **The Advantages**
- › The Applications
- › The System
- › Technology and Details
- › Service

Fiberoptic illuminators - Brightest Light. Special Contrasts. Highly Optimized.



You might have to distinguish fine details of dark colored specimen, or to evenly illuminate surface structures of large flat objects. You might want to look inside deep holes, or to get rid of annoying hotspots when imaging your glary specimen! Whenever your application demands higher brightness or better contrasts, decide for fiberoptic lighting! Powerful external light sources in combination with compact, highly specialized fiberoptic illuminators solve even most difficult illuminations tasks.

The CL6000 LED fiberoptic cold light source delivers intensive white light of daylight quality. Its high power LED engine reaches same brightness as a 150W halogen cold light source, and doesn't contain any infrared parts – for gentle specimen treatment.

Take advantage of the large range of fiberoptic light guides: There are ring illuminators for shadow-free illumination in bright- or darkfield, high brightness spots to create deliberate shadow effects, line light S for grazing illumination as well as diffuse dome and diffuse face light to soften reflections. Add polarization equipment to eliminate glare.



Inspect holes, threads and deepenings with vertical illuminator S. Its 45° mirror can be adjusted to avoid vignetting.



Line light S provides a homogeneous carpet of grazing light. Use it to contrast surface structures of large flat specimens with strong shadows.

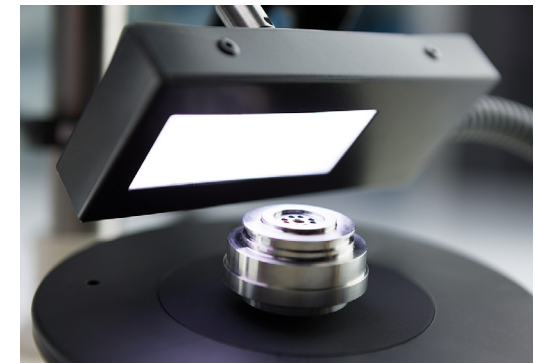

The diffuse face light S provides a soft light that prevents any strong reflections. Ideal for inspecting and imaging shiny surfaces.

Expand Your Possibilities

- › In Brief
- › **The Advantages**
- › The Applications
- › The System
- › Technology and Details
- › Service

Document and archive your results.

And share the images throughout your digital network.
It's full of possibilities.

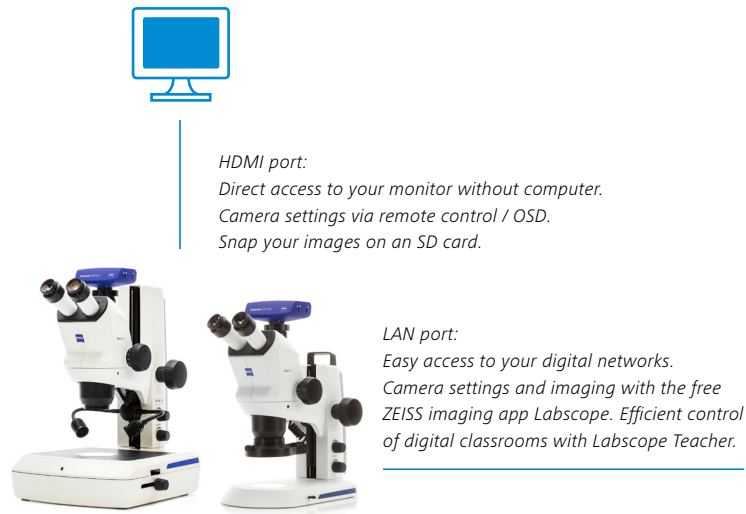

USB port:
Easy access to your Windows PC. Camera settings and imaging with the free ZEISS imaging software ZEN lite, ZEN starter or Labscope for Windows.



Use Stemi 508 with Axiocam ERc 5s or Axiocam 208 color and take advantage of its various interfaces to display the live window and snap your images.

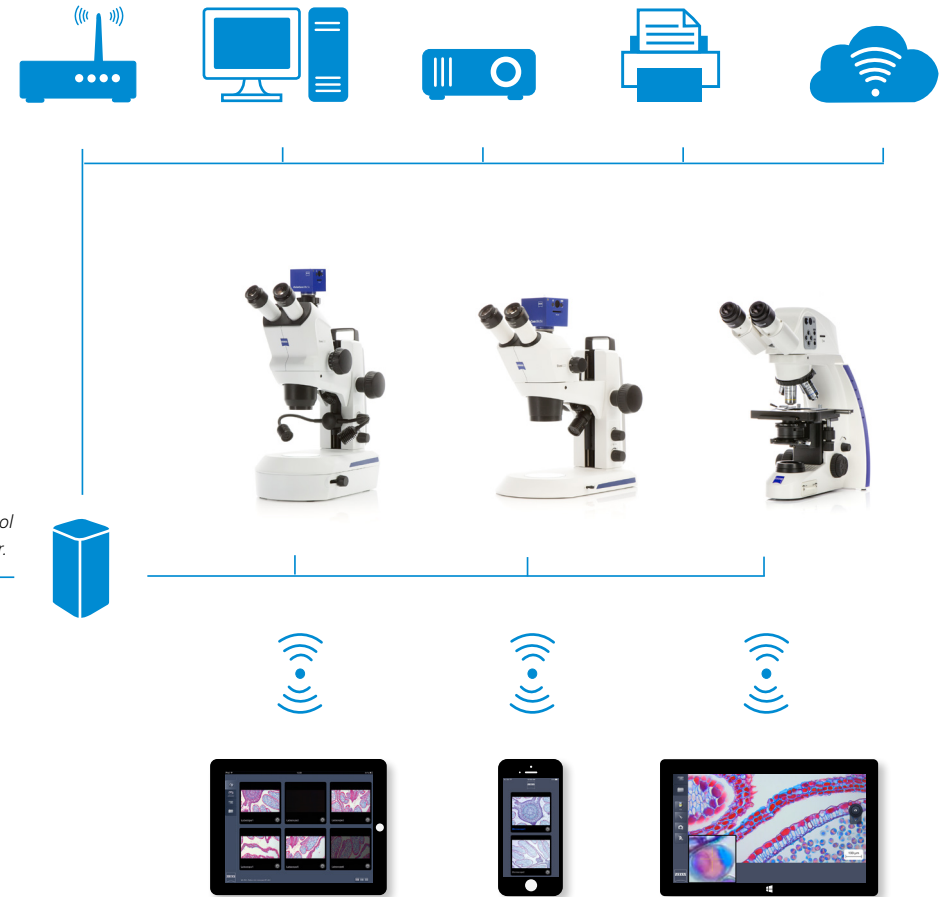

Connect several Stemi 508s and other ZEISS network-compatible microscopes – and transform your lab into a Wi-Fi enabled network. Simultaneously observe the live images of all connected microscopes on your iPads, iPhones or Windows PCs. With the imaging software Labscope you snap images, record videos and measure your microscopic samples easier than ever – and finally archive all results on your local server.

Tailored Precisely to Your Applications

- › In Brief
- › The Advantages
- › **The Applications**
- › The System
- › Technology and Details
- › Service

Typical Applications, Typical Samples	Task	ZEISS Stemi 508 Offers
Carry out advanced laboratory work in ... Developmental Biology	Observe development and growth of model organisms like spider crabs, chicken, mouse or zebra fish. Evaluate, sort, select or dissect eggs, larvae or embryos and use micromanipulators for injection. Document your results and prepare your samples for fluorescence imaging with light or confocal microscopes.	<ul style="list-style-type: none"> ■ Stemi 508 with 8:1 zoom delivers a high contrast stereoscopic image without color fringes or distortion. For relaxed stereoscopic viewing without eyestrain. The viewing angle of 35° provides an ergonomic sitting posture. ■ To reduce work space requirements use compact stand K LAB with mirror-based transmitted light unit. It delivers crisp or homogeneous brightfield, darkfield and oblique light. The latter is needed to contrast uncolored specimen like <i>C. Elegans</i>. To prepare samples in reflected light, integrate the double spot gooseneck. ■ For longer dissections the optional hand rest supports both of your hands. ■ When working with several petri dishes in parallel, you have the advantage of a large sample space and excellent oblique contrast by using stand M LED and transillumination unit M. ■ To investigate dark specimens, cold light source CL 6000 LED delivers intensive light of daylight quality. ■ Document highly resolved images using Stemi 508 doc with a ZEISS AxioCam microscope camera. To optimize transmission, 100 % light is switched between right eyepath and camera. For parallel view on a monitor and through eyepieces, e.g. to teach dissections, use Stemi 508 trino with permanent 50/50 split.
Botany	Observe changes in plant organs, parasitic or physiological plant diseases or root development	
Entomology	You observe, document and identify insects, sometimes in the field – for example, to map biotopes.	
Marine Biology	Observe conditions of life or reproduction of fish.	
Parasitology	Detect and identify spread of parasites.	
Geology, Paleontology	Collect and investigate assemblages of fossil foraminifera to determine the age of rock.	

Tailored Precisely to Your Applications

- › In Brief
- › The Advantages
- › **The Applications**
- › The System
- › Technology and Details
- › Service

Typical Applications, Typical Samples	Task	ZEISS Stemi 508 Offers
PCB Inspection	Check PCBs in the quality lab. Look for improper quality of contacts, engraving or wiring, metal or processing residues, and faulty solder joints. Document your results.	<ul style="list-style-type: none"> ■ Compact stand K MAT with segmentable ringlight is the right solution for limited space. Document your results with Axiocam 105 with 5 Megapixel resolution. ■ Use the 10 zoom click stops of Stemi 508 to reproduce your magnification easily. ■ To inspect and document shiny metal parts without strong reflections, create diffuse light using fiber optic diffusor S, diffuse face light S or the fluorescent tube ringlight. Use a ball-and-socket stage to tilt the specimen in a defined way.
Failure Search and Analysis	Search for reasons of faulty circuits and report your failure analysis.	
Diamond Industry	Evaluate quality of diamonds by visual inspection, find inclusions and impurities.	<ul style="list-style-type: none"> ■ Enjoy the large zoom range, high resolution, impressive image contrast and excellent color correction of Stemi 508.
Medical Devices	Assemble small high-precision components, e.g. in hearing aids or cardiac pulse stimulators.	
Sensor Manufacturing	Centre and align optical sensors or optical fibers.	
Clocks and Watches	Assemble small part components of watches, e.g. minute wheels, springs, cocks, bridges, pinions, bell and ratchet wheel screws, dial, mainspring, bolt and shoulder screws.	<ul style="list-style-type: none"> ■ Zoom from the whole watch in the overview up to the 8 times magnified detail. ■ During a long day, enjoy relaxed viewing with Stemi 508 and precise mechanics made for extensive use.
Printing and Engraving	Evaluate the surface quality of paper or engravings under grazing light.	<ul style="list-style-type: none"> ■ Stemi 508 offers fiber optic line light S for intensive grazing light with strong shadow effects. To see scratches on polished surfaces, use fiber optic darkfield ringlight. Use gliding stage S or stand base 300 with mechanical xy stage to screen the specimen in comfort.
Minted Coin and Medal Manufacturing	Inspect for scratches on proof quality silver coins.	
Forensics	Analyze ammunition parts, tool marks, documents, fibers, coatings, glass, textiles or hair.	<ul style="list-style-type: none"> ■ The apochromatic color correction of Stemi 508 with interchangeable front optics is essential for fiber analysis. ■ Achieve optimal contrast with the high brightness LED light of CL 6000 LED and the range of fiber optic light guides.
Art Restoration	Analyze, restore, clean and conserve paintings, sculptures and other works of art, analyzing layer by layer and identifying the material.	<ul style="list-style-type: none"> ■ Use flexible floor stand S or stable ball bearing stand SDA, along with shadow-free fiber optic ringlight. Benefit from Stemi 508's excellent image contrast and large field of vision.

ZEISS Stemi 508 at Work

- › In Brief
- › The Advantages
- › **The Applications**
- › The System
- › Technology and Details
- › Service

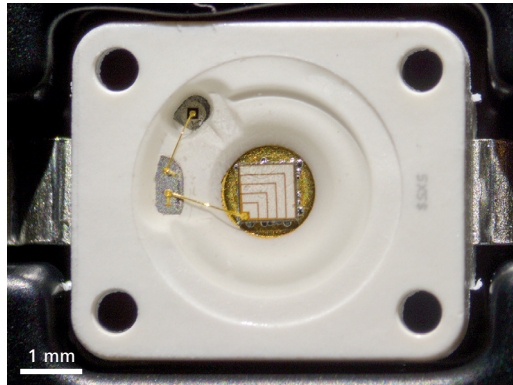

High brightness LED, chip, bond wires and packaging
Spot K LED, oblique reflected light, zoom 1.25x

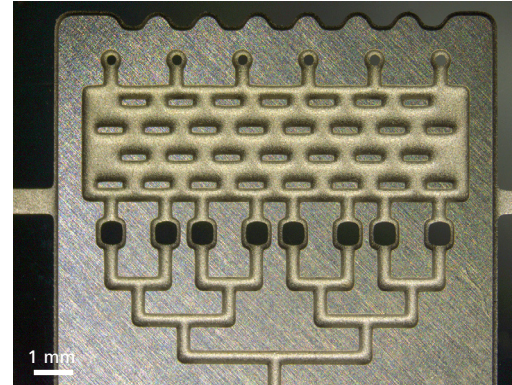

Microfluidic device
Segmentable ringlight K LED, half circle mode, zoom 0.8x

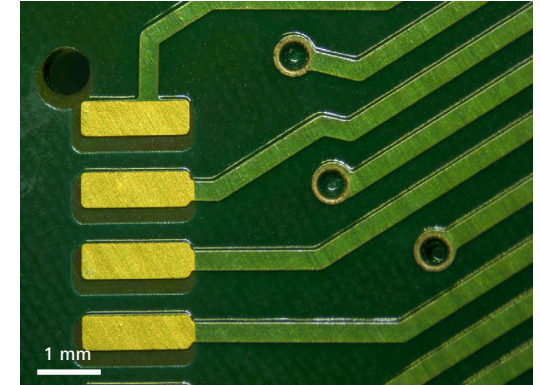

Printed circuit board
Segmentable ringlight K LED, quarter circle mode, zoom 1.25x



Powdery mildew (sawadaea) on Norway maple, cleistothecia
Spot K LED, reflected light darkfield, zoom 2.0x

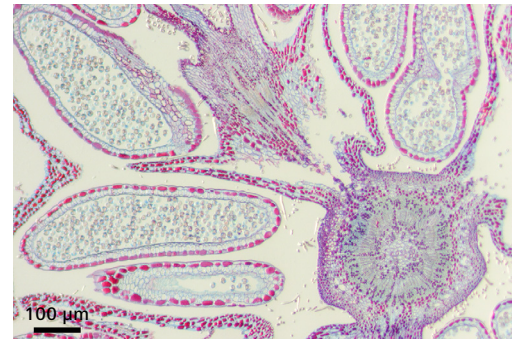

Hazelnut (corylus)
Transilluminator M LED, brightfield, zoom 5.0x



Royal fern, sori and sporangia
Spot K LED, oblique light, zoom 0.63x, front optics 5 Apo 0.63x

Your Flexible Choice of Components

- › In Brief
- › The Advantages
- › The Applications
- › **The System**
- › Technology and Details
- › Service

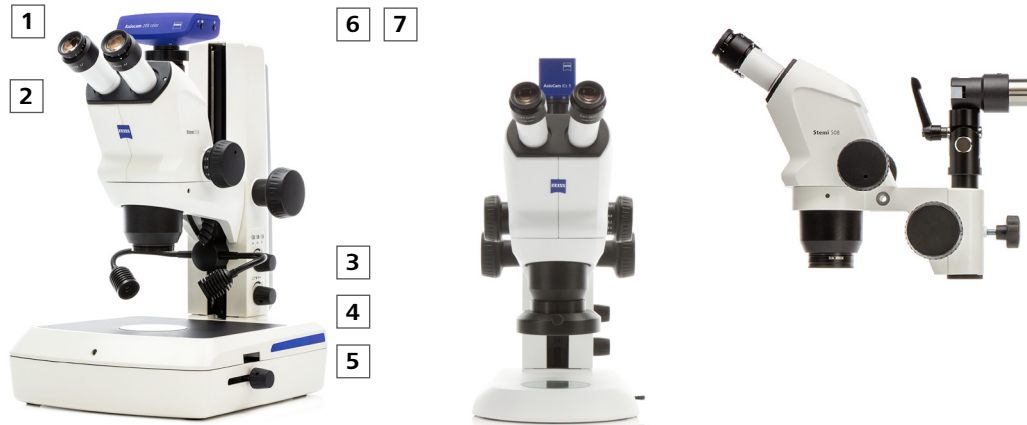

1 Microscopes

- Stemi 508 (binocular)
 - Stemi 508 doc (phototube 0/100 %, right path)
 - Stemi 508 trino (phototube 50/50 %, right path)
- All zoom bodies incl. eyepieces 10x/23 Br. foc and all phototubes with camera adapter 0.5x for c-mount cameras (changeable via 60N interface.)

2 Interchangeable Optics

- Eyepieces: PL 10x/23 Br. foc (included), PL 16x/16 Br. foc, W 25x/10 foc
- Front optics: 0.3x, 0.4x, Apo 0.63x, Apo 1.5x, Apo 2.0x, variable front optic 0.3x – 0.5x
- Accessories: eyepiece reticles, 60N adapter for C-mount, SLR and video cameras

3 Illumination

- LED illuminators to stands K/M: spot, double spot gooseneck, segmentable ringlight
- Flat or mirror-based transillumination units to Stand M LED
- Controller K for standalone use of ringlight K
- Fiberoptic cold light sources with spot, annular ring, line, vertical, diffuse dome and area illuminators
- High brightness LED spots and LED ringlights with segmenting function
- Polarization equipment for reflected and transmitted light

Illumination Techniques

- Reflected and transmitted light: brightfield, darkfield, polarization, oblique light

4 Stands

- Large desk top stands M and stand N with column 450 mm.
- Compact stands K
- LED stand versions K EDU/MAT/LAB and stand M LED with electronics and controls for LED illuminators
- Stable stand system 300 with C/F drive
- Boom stands B and double arm SDA
- Floor Stand S and tilting arm stand U

5 Accessories

- Mechanical, gliding, ball/socket and rotating stages, ergo hand rest for stand K LAB

6 Software

- ZEN lite and ZEN core imaging software
- Labscope imaging app for iPads or iPhones
- Labscope for Windows; Labscope Teacher

7 Recommended Cameras

- Axiocam ERc 5s
- Axiocam 105 color
- Axiocam 208 color

System Overview

- › In Brief
- › The Advantages
- › The Applications
- › **The System**
- › Technology and Details
- › Service

Stemi 508 - Microscope Bodies, Optics, LED Stands K/M

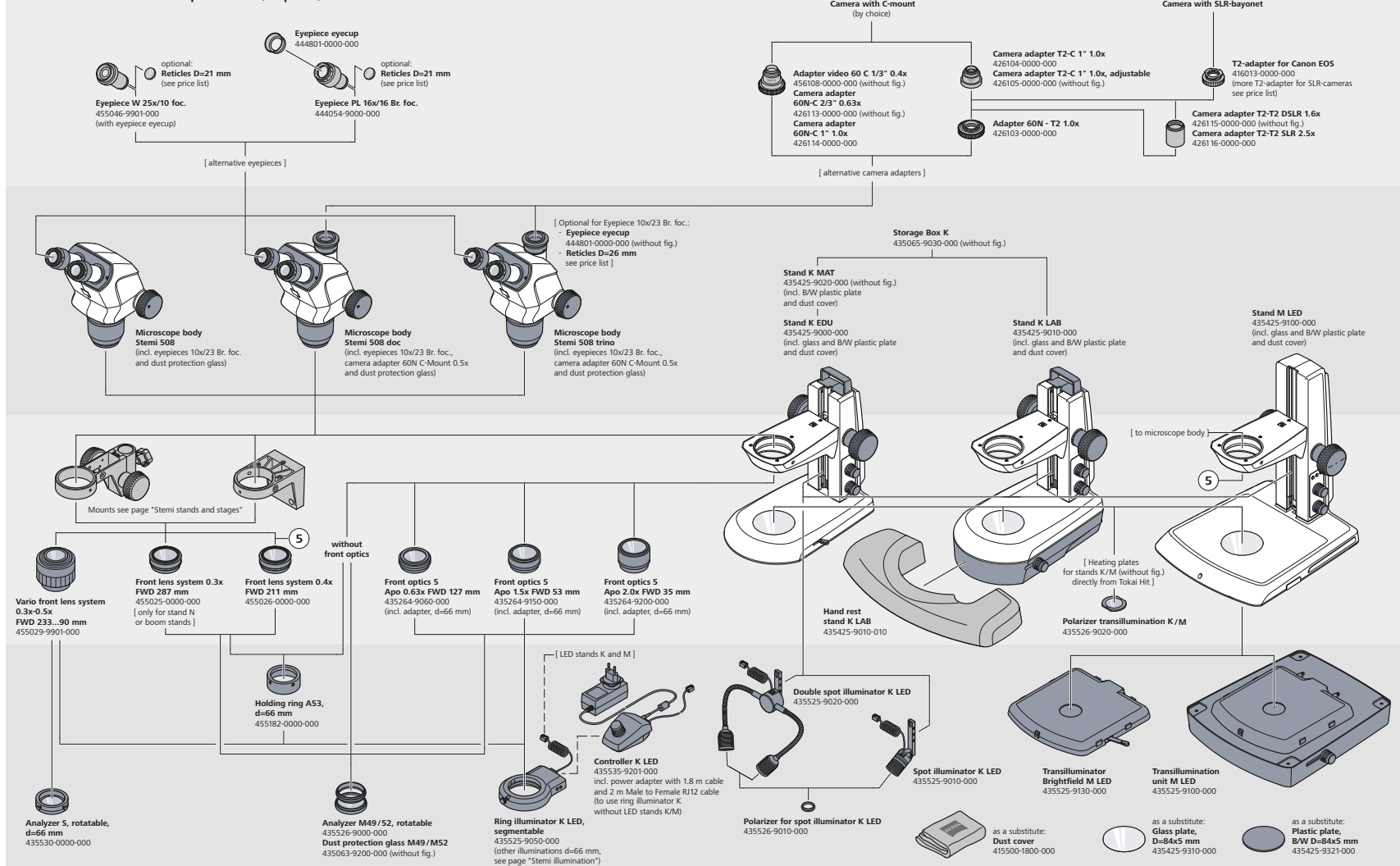

System Overview

- › In Brief
- › The Advantages
- › The Applications
- › The System
- › Technology and Details
- › Service

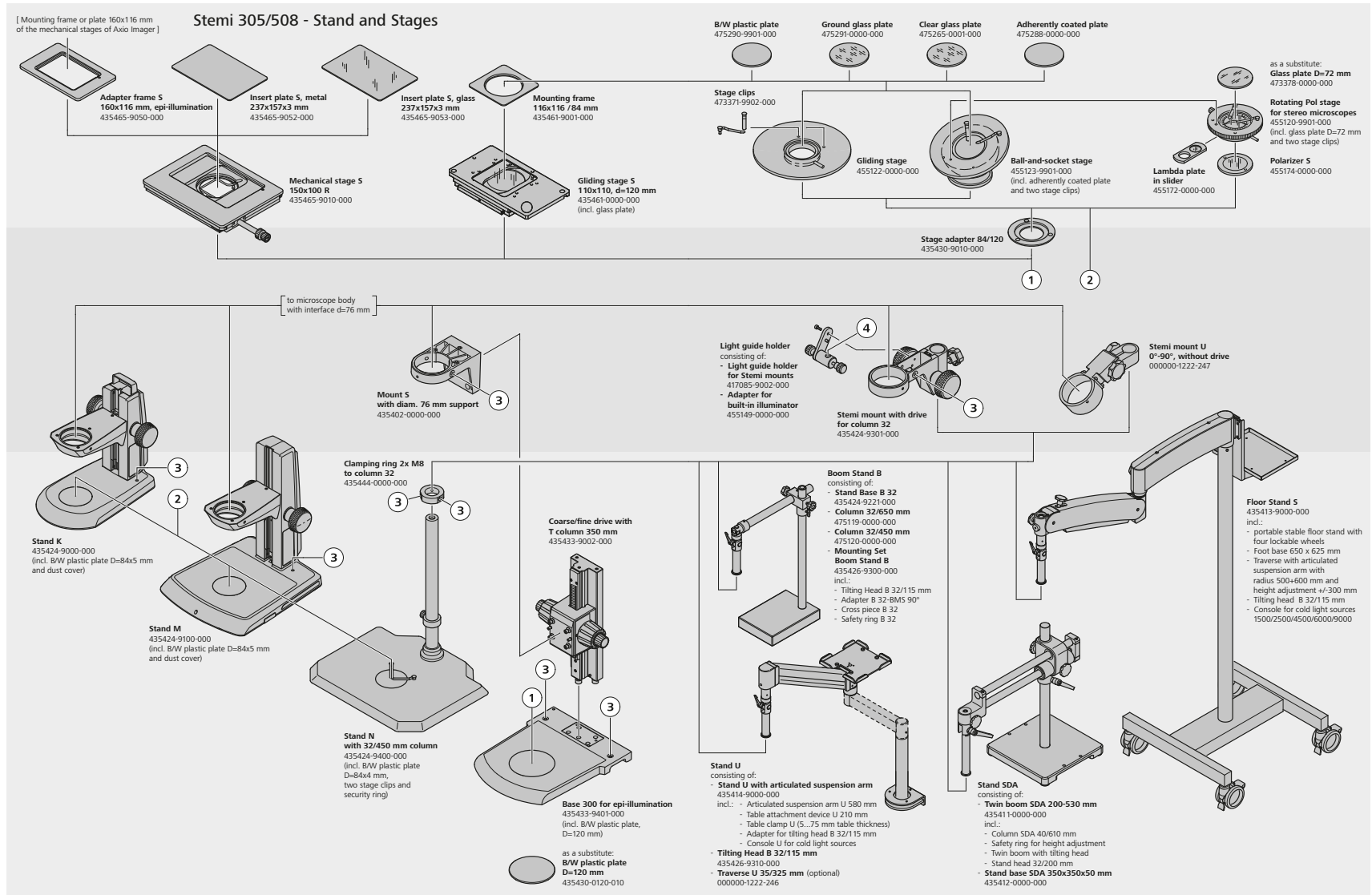

System Overview

- › In Brief
- › The Advantages
- › The Applications
- › **The System**
- › Technology and Details
- › Service

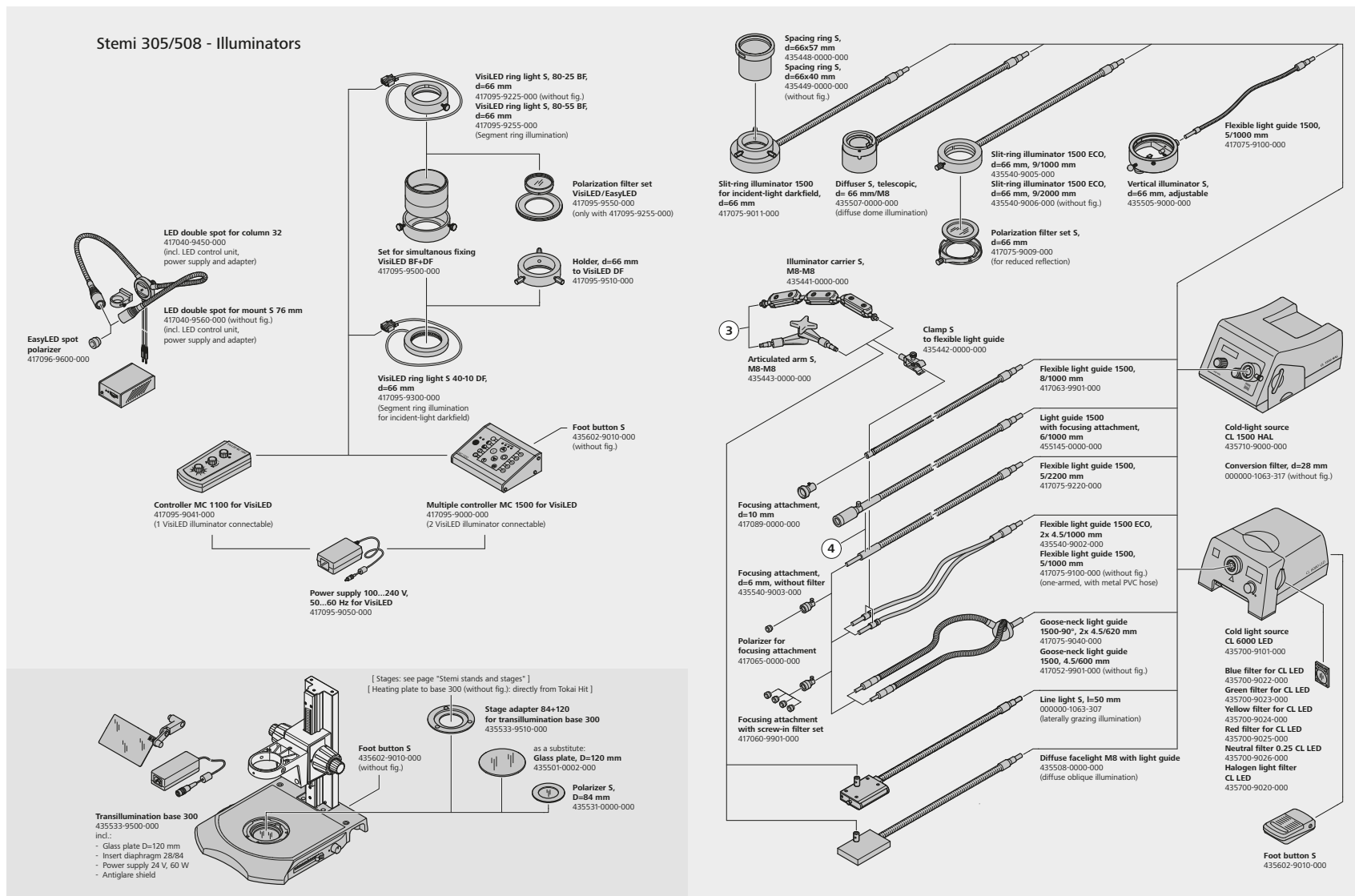

Technical Specifications

- › In Brief
- › The Advantages
- › The Applications
- › The System
- › **Technology and Details**
- › Service

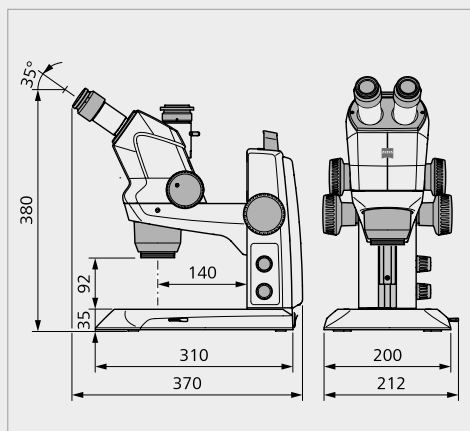

ZEISS Stemi 508 doc, stand K EDU

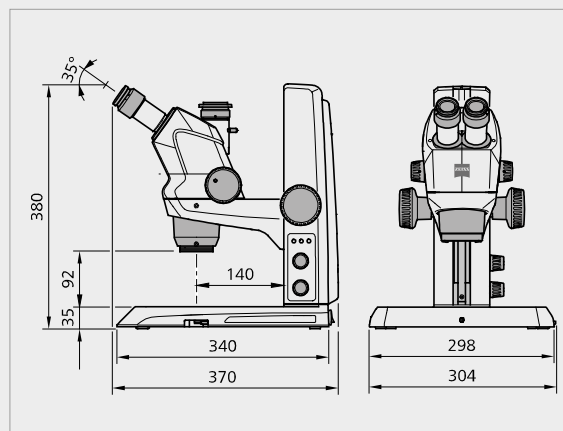

ZEISS Stemi 508 doc, stand M LED, flat transilluminator for brightfield/darkfield

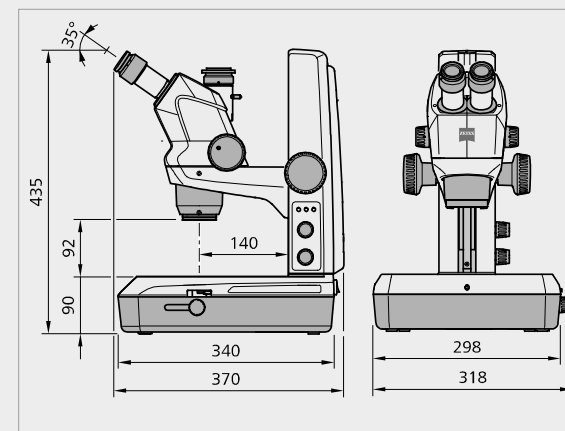

ZEISS Stemi 508, stand M LED, mirror based transillumination unit M

ZEISS Stemi 508		PL 10x/23 Br Foc				PL 16x/16 Br Foc				W 25x/10 Foc			
Front Optics	FWD	Total Magnification		Object Field [mm]		Total Magnification		Object Field [mm]		Total Magnification		Object Field [mm]	
		Min. Zoom	Max. Zoom	Min. Zoom	Max. Zoom	Min. Zoom	Max. Zoom	Min. Zoom	Max. Zoom	Min. Zoom	Max. Zoom	Min. Zoom	Max. Zoom
0.3	287	1.9	15.0	122.7	15.3	3.0	24.0	85.3	10.7	4.7	37.5	53.3	6.7
0.4	211	2.5	20.0	92.0	11.5	4.0	32.0	64.0	8.0	6.3	50.0	40.0	5.0
0.3 – 0.5	233 – 90	1.9	25.0	122.7	9.2	3.0	40.0	85.3	6.4	4.7	62.5	53.3	4.0
0.63	127	3.9	31.5	58.4	7.3	6.3	50.4	40.6	5.1	9.8	78.8	25.4	3.2
1x (without FO)	92	6.3	50.0	36.8	4.6	10.0	80.0	25.6	3.2	15.6	125.0	16.0	2.0
1.5	53	9.4	75.0	24.5	3.1	15.0	120.0	17.1	2.1	23.4	187.5	10.7	1.3
2.0	35	12.5	100.0	18.4	2.3	20.0	160.0	12.8	1.6	31.3	250.0	8.0	1.0

Technical Specifications

- › In Brief
- › The Advantages
- › The Applications
- › The System
- › **Technology and Details**
- › Service

Overall	
Type of Microscope	Stereo microscope, Greenough design
Design Principle	Two zoom systems, tilted by the stereo angle
Stereoscopic View	Threedimensional observation through eyepieces
Apochromatic Corrected Zoom and Front Optics	Image free of color fringes in complete magnification range
Optical Data Basic System (Eyepieces 10x, No Front Optics)	
Magnification Range	6.3x – 50x
Free Working Distance	92 mm
Maximum Resolution	Test slide: 225 Lp/mm Resolving power (Rayleigh criterion) $g = 4.4 \mu\text{m}$ Smallest Object Structure $g/2 = 2.2 \mu\text{m}$
Maximum Object Field Diameter	36.8 mm
Optical Data with Interchangeable Optics (Eyepieces, Front Optics)	
Accessible Magnification Range	1.9x – 250x
Free Working Distances	35 – 287 mm
Maximum Resolution	Test slide: 450 Lp/mm Resolving power (Rayleigh criterion) $g = 2.2 \mu\text{m}$ Smallest Object Structure $g/2 = 1.1 \mu\text{m}$
Maximum Object Field Diameter	122.7 mm
Microscope Bodies	Stemi 508, Stemi 508 doc and Stemi 508 trino microscope bodies (incl. eyepieces 10x/23 and dust protection glass)
Manual Zoom, Zoom Range	8:1 (0.63x...5.0x)
Quality of Zoom Optics	Distortion free, excellent contrast, apochromatic corrected
Parfocality of Zoom Optics	Object remains focused while zooming
Ergonomic Viewing Angle	35°
Adjustment of Interocular Distance	55 – 75 mm
Zoom Click Stops	10 Click Stop positions can be activated by choice: (End Stop 0.63x), 0.65x, 0.8x, 1x, 1.25x, 1.6x, 2x, 2.5x, 3.2x, 4x, 5x
Maximum Field Number	23 mm
Documentation Features Stemi 508 doc	Photoport with 100 % switch between right eyepath and camera, incl. interchangeable 60N c-mount camera adapter 0,5x
Documentation Features Stemi 508 trino	Photoport with 50/50 % permanent split between right eyepath and camera, incl. interchangeable 60N c-mount camera adapter 0,5x
Interfaces to Adapt	
Front Optics and Dust Protection Glass	M50 × 0.75
Pol Analyzer (to Front Optics, Dust Prot. Glass)	M49 × 0.75
Eyepieces	d = 30 mm
Stemi Mounts	d = 76 mm
Illuminators	d = 53 mm; Illuminators d = 66 mm via clamp ring d53/66 (optional)

Technical Specifications

- › In Brief
- › The Advantages
- › The Applications
- › The System
- › **Technology and Details**
- › Service

Large Desktop stand M system:	
Stand M	Mechanical stand for external fiberoptic illumination with 2× M8 interface for light guide carriers.
Stand M LED	Stand with integrated electronics for reflected/transmitted light LED illuminators K/M.
Both stands incl. BW plastic Plate D = 84×5 mm and Dust Cover. Stand M LED also incl glass plate and power cable Euro C8.	
Stand Base W300×D340×H35 mm:	
Working Surface	W255×D215 mm
Mechanical Interfaces	Interface for Stages d = 84 mm. Interface to retrofit Transillumination unit M or flat Transilluminator brightfield/darfield M. Interface for transmitted light polarizer d = 45 mm. Central through-hole 40 mm.
Stand Column with Stemi Mount and Focus Drive (Friction adjustable):	
Height / Lifting range	360 mm / 190 mm
Load capacity of Stemi mount	5 kg
Mechanical Interfaces	Interface for Stemi body d = 76 mm. Interface for Spot / Double Spot K LED.
Electronic features of Stand M LED:	
Two RJ12 sockets to retrofit reflected light illuminators	Single LED Spot K, Double Spot K and/or segmentable ringlight K
Sliding contacts for transmitted light illuminators	Cable-free adaption of LED Transillumination unit M or Transilluminator brightfield/darkfield M
On/off Switch	
Control knob for transmitted light	Push: on/off. Rotate: dimming
Control knob for two reflected light illuminators	Push sequentially: illuminator A → illuminator B → mixed light A+B → off. Rotate: dimming
Memory section to store three mixed light scenarios	Store and recall "on/off and brightness" of all adapted illuminators K/M (despite "segment settings" of ringlight K)
Integrated desktop power supply unit	12V DC 24W/100...240V AC/50...60Hz. With CE marking. UL, FCC and PSE approved. - Mounted behind focus column, easily changeable.
LED Illuminators for Stands M LED (optical specs see next page)	
LED Spot K	Height adjustable, tiltable, zoomable
LED Double Spot K	Height adjustable. Flexible positioning due to self carrying goosenecks.
Segmentable Ringlight K	Full/half/quarter circle, two opposing quarters. Segments rotatable in steps or continuous movement. Working distance typ 50 mm – 300 mm.
Flat Transilluminator M LED	Flat unit that doesn't add height to the stand. Quick switching between diffuse brightfield and all-sided darkfield.
Transillumination unit M LED:	Variable contrasting by rotatable and slidable mirror: Diffuse and crisp brightfield, oblique and one-sided darkfield illumination. Pol contrast optional

Technical Specifications

- › In Brief
- › The Advantages
- › The Applications
- › The System
- › **Technology and Details**
- › Service

Compact Stand K system:

Stand K	Mechanical stand for external fiberoptic illumination. With 2x M8 interface for light guide carriers. Central through-hole d = 40 mm
Stand K MAT	With interfaces/controls for reflected light illuminators K LED. Provides ESD features (antistatic surface resistance). Central through-hole d = 40 mm
Stand K EDU	With interfaces/controls for reflected light illuminators K LED and built-in flat transilluminator (brightfield / darkfield).
Stand K LAB	With interfaces/controls for reflected light illuminators K LED and built-in mirror based transillumination unit (brightfield / darkfield / oblique).

All stands incl. glass plate and/or BW plastic Plate D = 84x5 mm and dust cover. Stands K EDU/LAB/MAT incl country specific power cable Euro C8

Stand Base W200xD310xH35 mm (K Lab: H90 mm):

Working Surface	W160xD195 mm
Mechanical Interfaces	Interface for stages d = 84 mm. Interface for TL Polarizer d = 45 mm.

Stand Column with Stemi Mount, Handle and Focus Drive (Friction adjustable):

Height / Lifting range	250 mm / 145 mm
Load capacity of Stemi mount	5 kg
Mechanical Interfaces	Interface for Stemi body d = 76 mm. Interface for Spot / Double Spot K LED

Electronic features of stands K EDU/LAB/MAT:

On/off Switch. Separate control knobs for reflected and transmitted light (push: on/off, rotate: dimming).

Integrated desktop power supply, easily changeable: 12V DC 24W/100...240V AC/50...60Hz. With CE marking, UL, FCC and PSE approved

Optical specifications LED Illuminators K/M (for Stands M LED, Stands K EDU/MAT/LAB)

Color Temperature CCT [K]	Typ. 5600 K
Lifetime (Lumen Maintenance) [h]	Typ. 25000 h (operation time until the light intensity degraded to 70 % of initial value)
LED Spot K, max. brightness	Typ. 30000 lx (object field center, LED spot mounted to stand K EDU)
LED Double Spot K, max. brightness	Typ. 90000 lx (object field center, double spot mounted to stand K LAB)
Segmentable Ringlight K, max. brightness	Typ. 55000 lx (mounted to Stemi 508 body, object focused)
Transilluminator BF/DF M, max. brightness	Typ. 20000 lx (also true for transillumination base of stand K EDU)
Transillumination unit M, max. brightness	Typ. 25000 lx (also true for mirror transillumination base of stand K LAB)

Technical Specifications

- › In Brief
- › The Advantages
- › The Applications
- › The System
- › **Technology and Details**
- › Service

Stand N with column 450 / 32 mm	Large desktop stand with flexible column 32
Large Stand Base	W440 × D370
Column Height/Diameter	450 mm / d = 32 mm
Interface for Stages	d = 84 mm
Incl. black/white plate d = 84 mm and security ring. Additionally needed (not included): Stemi mount for column 32 with drive	
Stages for Interface d = 84 mm (suited for all desktop stands K / M / N)	
Gliding stage ±20 mm, rotatable, d = 84 mm	
Ball-and-socket stage ±30°, rotatable, d = 84 mm	
Rotating Pol stage for stereomicroscopes, d = 84 mm, with interfaces for polarizer, Lambda plate and specimen guide 75x25 mm for slides	
Boom Stands	
Single Arm Boom Stand B	
Stand base B 32 (dimensions, weight)	W280 mm x D200 mm x H47 mm, ~ 20.5 kg
Vertical column 32/650 mm (length/diameter)	650 mm / d = 32 mm
Horizontal column 32/450 mm (length/diameter)	450 mm / d = 32 mm
Mounting set Boom Stand B 32, consisting of:	Cross piece, adapter BMS, tilting head B 32 and safety ring
Stemi mount for column 32 with drive	With interface d = 76 mm for Stemi body. Lifting range 50 mm. Maximum load 5 kg. Focus drive with adjustable friction
Accessible Object Positions of Stemi 508 with boom stand B	
Working radius (distance vertical column to axis Stemi mount)	230 to 610 mm
Rotary adjustment range	360°
Object heights, vertical observation (Stemi 508 w/o front optics)	0 to 385 mm
Object heights, horizontal observation	up to 550 mm
Total weight of Boom Stand B (incl Stemi mount and Microscope) ~ 28 kg	

Technical Specifications

- › In Brief
- › The Advantages
- › The Applications
- › The System
- › **Technology and Details**
- › Service

Double Arm Boom Stand SDA

Stand base SDA (dimensions / weight)	W350xD350xH50 mm / ~ 30 kg	
Twin Boom SDA:	vertical column (length)	610 mm
	horizontal double arm, ball-bearing (length)	670 mm
	tilting head (column height / diameter)	200 mm / d = 32 mm
Stemi mount for column 32 with drive	With interface d = 76 mm for Stemi body. Lifting range 50 mm. Maximum load 5 kg. Focus drive with adjustable friction	

Accessible Object Positions of Stemi 508 with stand SDA

Working radius (distance vertical column to axis Stemi mount)	360 to 690 mm
Rotary adjustment range	360°
Object heights, vertical observation (Stemi 508 w/o front optics)	0 to 300 mm (Twin Boom mounted reverse: max. 920 mm)
Object heights, horizontal observation	~ 100 to 490 mm (Twin Boom mounted reverse: max. 820 mm)
Total weight stand SDA (incl Stemi mount and Microscope) ~ 57 kg	

Tilting Arm Stand U with Articulated Suspension Arm

Stand U:	table attachment device with column (height)	210 mm
	table clamp (for table thickness ...)	5 mm to 75 mm
	suspension arm (boom length / lifting range / load)	580 mm / 450 mm / max. 4.8 kg
	console for cold light source	e.g. CL4500 LED, CL6000 LED, CL9000 LED, CL1500 Hal
	adapter for tilting head B 32	
Traverse U (optional)	W320 x H60 mm, column diameter 32 mm, length 115 mm	
Tilting head B 32/115 (mandatory)		
Stemi mount for column 32 with drive (mandatory)	With interface d = 76 mm for Stemi body. Lifting range 50 mm. Maximum load 5 kg. Focus drive with adjustable friction	

Accessible Object Positions of Stemi 508 with stand U

Working radius (distance vertical column to axis Stemi mount)	up to 735 mm (with Traverse ~ 1060 mm)
Rotary adjustment range	360°
Object heights, vertical observation (Stemi 508 w/o front optics)	0 to 230 mm (with Traverse ~ 290 mm)
Object heights, horizontal observation	~ 100 to 480 mm
Total weight stand U (incl. Traverse, Stemi mount and Microscope) ~ 15 kg	

Technical Specifications

- › In Brief
- › The Advantages
- › The Applications
- › The System
- › **Technology and Details**
- › Service

Floor Stand S with Articulated Suspension Arm

Floor stand S:	Stand base, with four lockable wheels	W625 × D625 mm
	Stand column (height above floor)	~ 1730 mm
	Traverse (boom length)	500 mm
	Console for cold light source	
	Suspension arm (boom length / lifting range / height / load)	600 mm / 650 mm / max. 1880 mm above floor / max. 7 kg
	Tilting head with adapter to suspension arm	
	Stemi mount for column 32 with drive (order separately)	With interface d = 76 mm for Stemi body. Lifting range 50 mm. Maximum load 5 kg. Focus drive with adjustable friction

Accessible Object Positions of Stemi 508 with floor stand S

Working radius (distance vertical column to axis Stemi mount)	up to 1255 mm
Rotary adjustment range	360°
Object heights, vertical observation (Stemi 508 w/o front optics)	830 to 1480 mm (height above floor)
Object heights, horizontal observation	1000 to 1650 mm (height above floor)
Total weight Floor Stand S (incl. Stemi mount and Microscope) ~ 90 kg	

Technical Specifications

- › In Brief
- › The Advantages
- › The Applications
- › The System
- › **Technology and Details**
- › Service

Fiberoptic Illuminations

Cold Light Source CL 6000 LED

Light Engine	High power LED engine
Light Flux (output of ringlight, fiber bundle diam. 9 mm)	Max. 600 lm
Color Temperature	Typ. 6200 K. (Optional accessories: Daylight filter for a CCT of typ. 5600 K respectively Halogen Light filter for a CCT of typ. 3200 K)
Color Rendering Index	~ 80
LED Lifetime (Lumen Maintenance)	typ 50.000 h (operation time until the light intensity degrades to 70 % of initial value)
Light Guide Sensor	"Auto off" if no light guide is inserted
3 Pos. Filter Slider	For two filters (in filter holder) plus free opening
Wide-range Supply	100 – 240 V ± 10 %, 50 – 60 Hz, max. 50 W – open frame unit, integrated in the light source

Flicker free light, silent axial fan, 2.5 mm phone socket for foot button S

Cold Light Source CL 1500 HAL

Light Engine	150 W halogen reflector lamp
Light Flux (output of ringlight, fiber bundle diam. 9 mm)	Max. 600 lm at 100 % dimming / ~ 450 lm at 80 % dimming
LCD Display	Displays brightness level / color temperature / power-on hours
Bulb Lifetime at dimming level 50 / 80 / 100 %	Typ 1500 h / 150 h / 50 h
2 Pos. Filter Slider	For one filter (d = 28 mm without filter holder) plus free opening
Wide-range Supply For Flicker Free Light, Silent Axial Fan	100 – 240 V ~ 50 – 60 Hz, max. 180 W – open frame unit, integrated in the light source

Light Guides

Single and double spot flexible light guides	Flexible sheathing. For oblique light; crisp 3d impression by distinct shadows. Precise positioning via supporting arms (order separately).
Single and double spot gooseneck light guides	Self supporting. For oblique light; crisp 3d impression by distinct shadows
Annular ring illuminators D = 66 mm for Brightfield	Shadow free illumination
Annular ring illuminators D = 66 mm for Darkfield	Shadow free illumination. Gliding stage recommended.
Line light 50 mm	Homogeneous grazing light to emphasis structures of flat surfaces. Positioning via supporting arm (order separately). Gliding stage recommended.
Vertical illuminator	For illumination of deepenings and holes. Needs supporting flexible spot light guide.
Diffusor S	Shadow free all sided soft light, "cloudy day illuminator"; to avoid glare. Ball-and-socket stage recommended.
Diffuse area light	One sided "soft" illumination; to avoid glare but also create certain shadows. Positioning via supporting arm (order separately).

Illumination Accessories

Focusing optics for spot light guides	Increase brightness
Polarizing equipment for spots and ringlights	Reduce reflections

Technical Specifications

- › In Brief
- › The Advantages
- › The Applications
- › The System
- › **Technology and Details**
- › Service

Ambient Conditions

Storage (in Packaging)

Permissible Ambient Temperature	+10 to +40 °C
Permissible Relative Humidity	Max. 75 % at +35 °C (without condensation)

Transportation (in Packaging)

Permissible Ambient Temperature	-40 to +70 °C
---------------------------------	---------------

Operation

Permissible Ambient Temperature	+10 to +40 °C
Permissible Relative Humidity	Max. 75 %
Air Pressure	800 hPa to 1060 hPa
Degree of Pollution	2
Area of Use	Closed rooms
Max. Altitude	Max. 2000 m

Operational Data – Power Supply unit for stand M LED, stands K EDU/LAB/MAT and Controller K LED

Protection	Class II
Protection Type	IP 20
Electrical Safety	Acc. to DIN EN 61010-1 (IEC 61010-1)
Degree of Pollution	2
Overvoltage Category	2
Wide range input voltage	100 to 240 V ±10 %, Converting the line voltage is not necessary!
Power Frequency	50 Hz – 60 Hz
Power Consumption	Max. 40 VA
Output voltage	12 V DC, max. 2 A
Input Output	100 – 240 V, 50 – 60 Hz, max. 0.55 A
Markings / approvals	CE marking

Note: Anti-fungus treated

Count on Service in the True Sense of the Word

- › In Brief
- › The Advantages
- › The Applications
- › The System
- › Technology and Details
- › **Service**

Because the ZEISS microscope system is one of your most important tools, we make sure it is always ready to perform. What's more, we'll see to it that you are employing all the options that get the best from your microscope. You can choose from a range of service products, each delivered by highly qualified ZEISS specialists who will support you long beyond the purchase of your system. Our aim is to enable you to experience those special moments that inspire your work.

Repair. Maintain. Optimize.

Attain maximum uptime with your microscope. A ZEISS Protect Service Agreement lets you budget for operating costs, all the while reducing costly downtime and achieving the best results through the improved performance of your system. Choose from service agreements designed to give you a range of options and control levels. We'll work with you to select the service program that addresses your system needs and usage requirements, in line with your organization's standard practices.

Our service on-demand also brings you distinct advantages. ZEISS service staff will analyze issues at hand and resolve them – whether using remote maintenance software or working on site.

Enhance Your Microscope System.

Your ZEISS microscope system is designed for a variety of updates: open interfaces allow you to maintain a high technological level at all times. As a result you'll work more efficiently now, while extending the productive lifetime of your microscope as new update possibilities come on stream.

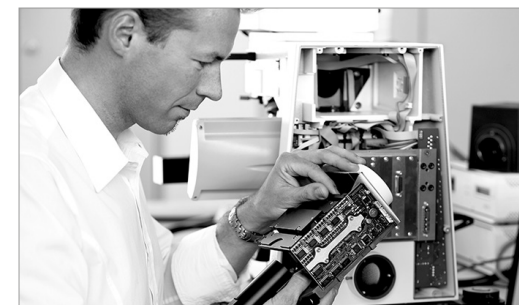

Profit from the optimized performance of your microscope system with services from ZEISS – now and for years to come.

>> www.zeiss.com/microservice



Carl Zeiss Microscopy GmbH
07745 Jena, Germany
microscopy@zeiss.com
www.zeiss.com/stemi508

